

DİKİLİ TİP YAN KAPAK MONTAJ
WALL MOUNT DOOR TYPE

DIŞ ORTAM KLİMASI
OUTDOOR TYPE COOLING UNIT

A SINIFI EKİPMAN
A CLASS EQUIPMENT

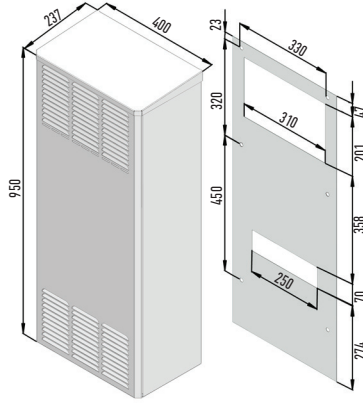
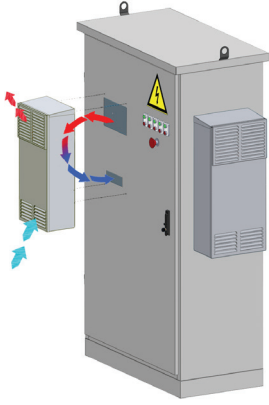

TEKNİK BİLGİLER

TECHNICAL DETAILS

0-2000

Soğutma Kapasitesi (L35 / L35)	Cooling Capacity (L35 / L35)	1700 W
Soğutucu Gaz Tipi	Type Of Refrigerant	R 134a
Soğutucu Gaz Miktarı	Amount Of Refrigerant	520 gr
Fabrika Termostat Ayar Değeri	Default Thermostat Setting	34 °C
Difransiyel	Hysteresis	4 °C
Dış Ünite Fan Debisi	External Circuit	945 m ³ /h
İç Ünite Fan Debisi	Internal Circuit	945 m ³ /h
Enerji Frekansı	Rated Frequency	50/60 Hz
Standart Güç	Standard Power Supply	198 V...252 V
Çekilen Güç	Power Absorbed L35 L35	890 W
Çalışma Akımı	Running Current	4.2 A
Başlangıç Akımı	Starting Current	17.2 A
Ağırlık	Weight	40 kg
Yükseklik x Genişlik x Derinlik	Height x Width x Depth mm	950 X 400 X 237
Metal Aksam Cinsi	Corrosion Protection (cover)	Galvanized
Montaj Şekli	Orientation	Wall Mount
Koruma Sınıfı	System of Protection	IP 65
Çalışma Aralığı	Ambient Air Temperature	0°C +55 °C
Kompresör	Compressor	Danfoss-Secop
Fanlar	Fans	EbmPapst

