

## 3104 ELECTRONIC SWINGHANDLE



**MATERIALS**  
 BODY: Polyamide DIN-EN ISO 1043-1 PA6 GFR 30  
 HANDLE: Polyamide DIN-EN ISO 1043-1 PA6 GFR 30  
 CAM: Steel

In case of power outage remove the dust cover on the handle and open with the key.

Open-close position of door can be monitored. The max distance between the magnet and the lock is 10 mm.

SPECIFICATIONS					DD
Stainless steel dust cap (Keyed alike)					40
Stainless steel dust cap (Keyed differ)					32

Group Code	Handle	Body	Cylinder	Cam
	2	0	2	0
			DD	CC

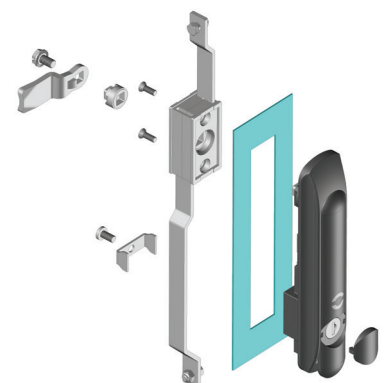

For cams and rods, please check  
 ▶ Page: 170 -178